

COMPACT POWERLIFT

Power on the go! Rev 004

With its multi-purpose design, the *Compact Powerlift* makes a great all around depositing system with more power and faster depositing speed than our larger depositors, yet is smaller in design! The *Compact Powerlift* can be fitted with a full range of Unifiller attachments and comes equipped with a powered height adjustment that drops the Hopper to floor level for easy filling and convenient operation.

System Includes

- Compact depositor fitted with 2.5” product cylinder and piston size
- Large conical hopper—14 US gallon capacity
- Depositing table—removable and fully height adjustable
- Foot operated starter switch (step for single shot or hold for multiple shots)
- Fitted with spout nozzle
- All stainless steel construction frame with powered height adjustment –machine base drops to floor level for easy filling and can be operated at any height

Common Applications

- Batter for cakes, muffins, etc.
- Fruit filling for pies and pastries
- Icings, frostings & toppings
- Jams and jellies
- Creams, custards & mousse
- Anything that can be squeezed through a pastry bag!

Product Cylinder Size Chart

CYLINDER SIZE	DEPOSIT VOLUME (fl oz)			
	Min		Max	
3”	1.8 oz	53 ml	18 oz	532 ml
2.5”	1.2 oz	36 ml	12.3 oz	363 ml
2”	0.8 oz	23 ml	7.6 oz	226 ml
1.5”	0.4 oz	12 ml	4.1 oz	122 ml
1”	0.3 oz	10 ml	1.7 oz	48 ml

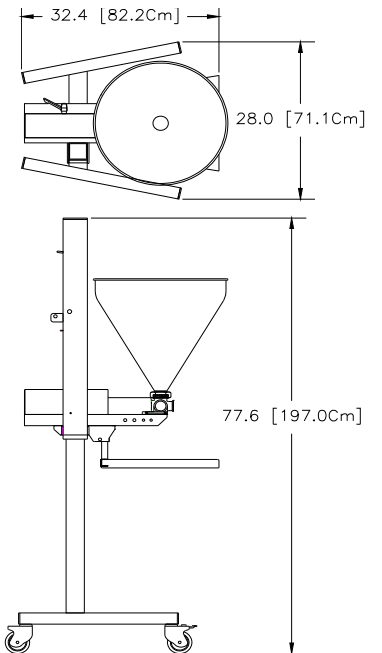

Shipping Information

L 36” x W 30” x H 52”

Shipping weight: 200 lbs.

Dashboard Specifications



Speed
Up to 140 deposits/min (8400 deposits/hr).
Based on product size



Power
80 PSI @ 3 – 5 CFM
5.5 Bar @ 85-141.5 litres per minute



Volume
0.3 oz to 18 oz.
10ml to 532ml



Particle Size
Up to 3/4" cube
19mm

Terms and Conditions

Delivery Estimated at 2 - 6 weeks from receipt of down payment, based on production schedule at the time of order.

Note: Delivery of the ordered equipment may be affected if the requested technical information and product details from the customer are not returned to our engineering department in a timely manner.

Installation Available at additional charge – see your sales representative for details.

E.X.W. Delta

Pricing All prices are valid for 60 days from quotation.

Performance The equipment quoted is designed to run at the speeds given, but is dependent on operator efficiency and skill, as well as deposit size and product consistency.

Taxes Local and/or State taxes are not included in the sale price and are the sole responsibility of the customer.

Payment Terms **35%** payment with order
55% when tested, inspected, and ready to ship
10% due 30 days from delivery
All machines remain the property of Unifiller Systems, Inc. until paid in full

**See your sales representative for complete terms and conditions

Unifiller Systems Inc.

7621 MacDonald Road, Delta, B.C., Canada, V4G 1N3
Phone: (604) 940-2233 Toll-free: (888) 733-8444 Fax: (604) 940-2195
www.unifiller.com Email: general@unifiller.com